

MASTERFLOW[®] 928

Ready-To Use, Non-Shrink, High Strength Grout

Description of Product

MASTERFLOW[®] 928 is a specially prepared, ready-to-use, non-shrink, high-strength grout. It is formulated for use at any consistency from fluid to damp pack for precision grouting of equipment, concrete systems, structural building members, curtain walls, precast wall panels, beams and columns. It contains natural aggregates and provides a grout that is similar in appearance to concrete and mortar. MASTERFLOW[®] 928 is the ideal product to use for a natural coloured grout.

Fields of Application

MASTERFLOW[®] 928 is recommended for:

- Grouting and precision equipment, baseplates, soleplates and columns.
- Grouting applications where shrinkage must be eliminated and where high-strength grout similar in appearance to concrete and mortar is required or desired.
- Non-shrink grouting of precast wall panels, beams and columns.
- Anchoring bolts, reinforcing bars and rods.

Features and Benefits

- A ready-to-use grout that hardens free of bleeding, settlement or drying shrinkage when mixed and placed at any consistency - fluid, flowable or plastic.
- A grout that retains good workability for up to 1 hour at 20°C.
- A non-shrink grout that can be pumped into intricate areas or areas inaccessible to conventional grouting methods.
- A non-shrink grout for use where a grout similar in appearance to concrete and mortar is required and desired.
- A grout that develops high strengths at flowable consistency without vertical confinement.
- Can be applied in thicknesses ranging from 10-75 mm.

Typical Properties/ Technical Data

Plastic density	2160 kg/m ³	
Plastic expansion (ASTM C827)	+0.2%	
Hardened expansion(CRD621)	+0.2%	
Bleed	Nil	
Air content	3.5%	
Flexural Strength (BS 6319:Pt7)	7 days	7.5 N/mm ²
	28 days	8.5 N/mm ²
Compressive strengths of MASTERFLOW [®] 928 (at 20%)		
Consistency		
	Plastic (1) N/mm ²	Fluid (2) N/mm ²
1 day	40	23
3 days	58	35
7 days	68	46
28 days	80	60
Average air content:	4.2%	
(1) 95% flow on flow table , ASTM C230, 5 drops in 3 seconds		
Plastic consistency at 3 litres of water per 25 kg bag		
(2) 25 -30 seconds flow, by Corps of Engineers Flow Cone Method CRD-C 611 or Cerilh Cone Method		
Fluid consistency at 4.6 litres of water per 25 kg bag		

Note

The data shown is based on controlled laboratory tests. Reasonable variations from the results shown can be expected. Field and laboratory tests should be controlled on the basis of the desired placing consistency rather than strictly on the water content.

Application Procedure

Preparation of Substrate

The substrate onto which the grout is to be applied should be mechanically prepared to remove laitance and expose aggregate. The substrate must be sound and free of oil, dust, dirt, paint, curing compounds and other contaminants. Soak area to be grouted with water for a minimum of 3 hours prior to grouting to minimise localised absorption and to assist in the free flow of the grout. Substrates should be damp but free of standing water. Particular attention should be paid to bolt holes to ensure that these are water-free. Use vacuum and/or oil free compressed air to remove free standing water.

Base plates, bolts, etc. must be clean and free of oil, grease, paint and other contaminants. Set and align equipment. If shims are to be removed after the grout has set, then lightly grease them for easy removal.

Formwork

Ensure formwork is secure and watertight to prevent movement and leaking during the placing and curing of the grout. The area should be free of excessive vibration. Shut down adjacent machinery until the grout has hardened. Formwork should be designed to allow a hydrostatic head of 150mm to be maintained throughout. On the side where the grout is to be poured, allow 150mm clearance between the sides of the form and the base plate of the machine.

On the opposite side allow at least 50-100mm for the head of the grout and 50mm clearance between the formwork and the edge of the base plate.

Mixing

For optimum results a high shear paddle or vane grout mixer should be used. Colloidal impeller mixers are not suitable for use with this product. Air entrainment should be avoided.

For large or continuous placement ensure that adequate mixing capacity and sufficient labour is available. A holding tank fitted with agitation may be required.

Add the correct amount of water for the required consistency to the mixer and then add the complete pack(s) slowly while mixing. Mix for 3-5 minutes depending upon mixer, until a smooth, uniform, lump free consistency is achieved.

The following indicates the appropriate quantity of water required to mix a 25Kg bag of MASTERFLOW® 928 grout to various consistencies at the temperature shown.

Water demand (litres per 25kg bag)			
Consistency	Fluid	Flowable	Plastic
Temperature 20°C	4.6	4.2	3.0

A trial mix may be required to establish the correct water content, which will depend upon mixing equipment and site temperatures.

Application Underplate:

Ensure sufficient material is available to complete the work and obtain a continuous fill.

Fill all the bolt pockets with grout before pouring the rest of the underplate grout. Pour the grout continuously from one side only to avoid air entrapment. Maintain a constant hydrostatic head of approximately 150mm, to promote flow. DO NOT vibrate. Lengths of metal or plastic strapping laid in the formwork prior to placing can be used to aid complete filling.

Grouting large volumes:

Where the thickness of grout exceeds 75 mm the addition of clean, graded 10mm aggregates at up to one to one by weight is recommended. In this instance normal concrete mixers and pumps may be used. Alternatively Emaco S103 can be used.

Pumping:

MASTERFLOW® 928 may be placed using piston, ram or diaphragm type grout pumps fitted with ball valves.

Placing techniques:

Diagram (A) illustrates typical placement of MASTERFLOW® 928 in the flowable state utilising straight pouring or pumping techniques to place a bedding mortar under bearing plates. Note that unrestrained areas around baseplates should always be kept to a minimum.

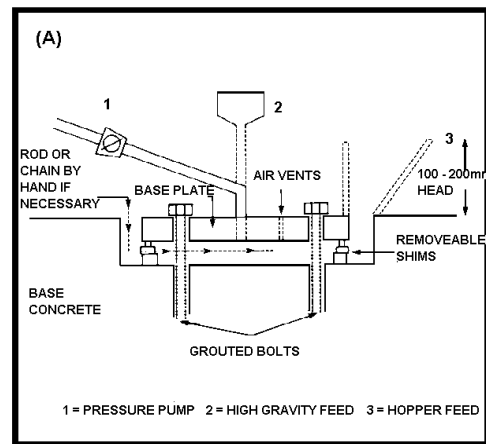

Unrestrained areas

Even with good curing, unrestrained areas of grout, for example around baseplates, may exhibit drying shrinkage cracking some time after placement. This is not detrimental to the performance of the grout where it is restrained under the plate or bearing, but may affect the cosmetic appearance of the application.



The Chemical Company

Curing

Good curing is essential on all exposed surfaces particularly in dry, sunny conditions. Failure to do so will reduce bond, strength and durability. Immediately after finishing apply 1 coat of MASTERKURE® 191 or 181 to all exposed surfaces. Alternative methods are water ponding, mist spraying and the like, but in all cases these must be maintained for at least 7 days. Keep the grout above 5°C at all times during application and cure.

Caution

Contact BASF Construction Chemicals (UK) Ltd for information on other products suitable for use in grouting prestressed and post tensioned cables and rods designed for stresses in excess of 550 N/mm².

Yield

25 kg of MASTERFLOW® 928 mixed with 4.6 litres of water produces 13.7 litres of grout.
73 x 25 kg bags of grout per m³. Using more or less water to meet consistency requirements, will increase or decrease the yield accordingly. When estimating due allowance for wastage must be made.

Packaging

MASTERFLOW® 928 is packed in 25 kg bags.

Storage

Store in cool dry conditions away from direct sunlight and at ambient temperatures.

Shelf Life

Up to 1 year when stored in unopened containers depending upon storage conditions.
Refer also to best before date.

BASF Construction Chemicals (UK) Ltd

PO Box 4

Earl Road

Cheadle Hulme

Cheadle

Cheshire

SK8 6QG

Tel: +44 (0) 161 485 6222

Fax +44 (0) 161 488 5220

www.basf-cc.co.uk

MASTERFLOW® 928 BASF Construction Chemicals UK Ltd Version 9 – July 2008

Health and Safety

*For full information on Health and Safety matters regarding this product the relevant Health and Safety Data Sheet should be consulted.

The following general comments apply to all products.

As with all chemical products, care should be taken during use and storage to avoid contact with eyes, mouth, skin and foodstuffs, (which may also be tainted with vapour until the product is fully cured and dried). Treat splashes to eyes and skin immediately. If accidentally ingested, seek medical attention. Keep away from children and animals. Reseal containers after use.

Powder Products

Should be handled to minimise dust formation; use light mask if excessive dust unavoidable. Cement powders when wet or moistened can cause burns to skin and eyes which should be protected during use.

Spillage

Chemical products can cause damage; clean spillage immediately.

Disclaimer:

This information and all further technical advice is based on our present knowledge and experience. However, it implies no liability or other legal responsibility on our part, including with regard to existing third party intellectual property rights, especially patent rights. In particular, no warranty, whether express or implied, or guarantee of product properties in the legal sense is intended or implied. We reserve the right to make any changes according to technological progress or further developments. The customer is not released from the obligation to conduct careful inspection and testing of incoming goods. Performance of the product described herein should be verified by testing, which should be carried out only by qualified experts in the sole responsibility of a customer. Reference to trade names used by other companies is neither a recommendation, nor does it imply that similar products could not be used.