

# MASTERFLOW<sup>®</sup> 101

## High Early Strength Fast Set, Pouring Grade, Flowable Epoxy Bedding Compound and Grout

### Description of Product

MASTERFLOW<sup>®</sup> 101 is a three component pouring grade flowable epoxy bedding compound formulated to withstand static and dynamic loads in a wide variety of applications.

MASTERFLOW<sup>®</sup> 101 is durable, non-shrink, high strength and resistant to chemical attack. The non-shrink properties and high early strengths of MASTERFLOW<sup>®</sup> 101 make it ideal for machinery bedding, where early re-commissioning times are required. It is particularly suitable for situations where dynamic loading prohibits the use of cementitious grouts.

MASTERFLOW<sup>®</sup> 101 complies with Dtp clause 2601. Specification for Highway Works - Bedding Mortars.

MASTERFLOW<sup>®</sup> 101 conforms to the specifications of ASTM C881: Type 1, grade 2, class B & C.

### Fields of Application

- Fast set high early strength filling of bolt holes and around securing bolts.
- Bedding machinery for earlier use.
- Crane rails, light railtracks.
- Bedding of bridge bearing plates.
- Jointing pipes.

### Features and Benefits

- High early strength reduces down time.
- Pourable & flowable consistency.
- Non shrink during cure.
- Resistant to chemical attack therefore suitable for harsh environments.
- Strong adhesion to concrete & steel.
- Very high flexural and tensile strength.
- Excellent impact resistance able to withstand dynamic loading.
- Can be applied in thicknesses ranging from 10-75mm

### Technical Data/Typical Properties

Colour	Grey
Compressive strength (BS 6319 Pt.2)	@ 20°C >70N/mm <sup>2</sup> @ 24 hours
Flexural strength (BS 6319 Pt.3)	40N/mm <sup>2</sup>
Tensile strength (BS 6319 Pt.7)	12N/mm <sup>2</sup>
Dept of Transport Clause 2601 Test Data:	
Elastic Stability	Strain 0.7%
Volume change	Negligible
Water Absorption	0.19%
Flow	Satisfactory
Service temperature	-20°C to +60°C
Final cure	5-7 hour dependant on ambient temperature
Density	2000 kg /m <sup>3</sup>
Pot life	@ 10°C - 90 mins @ 25°C - 25 mins

### Note

The data shown is based on controlled laboratory tests. Reasonable variations from the results shown can be expected. Field and laboratory tests should be controlled on the basis of the desired placing consistency.

### Chemical resistance

The resistance of MASTERFLOW<sup>®</sup> 101 to most common corrosive chemicals is excellent, including: Sewage, fresh water, sea water, dilute and concentrated alkalis, some dilute acids, mineral, vegetable and animal oils and fats, ammonia.

### Application Procedure

#### Concrete preparation and sealing

The substrate onto which the grout is to be applied should be mechanically prepared to remove laitance and expose aggregate. The substrate must be sound and free of oil, dust, dirt, paint, curing compounds and other contaminants. Particular attention should be paid to bolt holes to ensure that these are water-free. Use vacuum and/or oil free compressed air to remove free standing water. The concrete surface must be clean and dry when the grout is poured. The concrete areas to be grouted should not be primed or sealed.

#### Preparation and priming of metal surfaces

Base plates, rails and other metal surfaces to be grouted should be cleaned to SA 2½ to obtain proper adhesion. Priming the metal surfaces is only required when a long delay between cleaning and grouting will allow corrosion and contamination.

Base plates, bolts, etc. must be clean and free of oil, grease, paint and other contaminants. Set and align equipment. If shims are to be removed after the grout has set, then lightly grease them for easy removal.

#### Formwork

Ensure formwork is secure and leakproof to prevent movement and grout loss during the placing and curing of the grout. The area should be free of excessive vibration. Shut down adjacent machinery until the grout has hardened. Formwork should be designed to allow a hydrostatic head of 150mm to be maintained throughout.

On the side where the grout is to be poured, allow 150mm clearance between the sides of the form and the base plate of the machine.

On the opposite side allow at least 50-100mm for the head of the grout and 50mm clearance between the formwork and the edge of the base plate.

#### Mixing

Add all the contents of the hardener container to the resin component and mix thoroughly for at least 3 minutes. Transfer to a mechanical mixer. Add the aggregate, mixing thoroughly until a uniform consistency is obtained.

At low temperatures (between 5°C and 10°C) the flow characteristics of MASTERFLOW® 101 will be reduced and installation times increased.

To improve flow, up to 25% of the inert filler can be removed per pack. This will allow installation in gap widths below the minimum thickness of 10mm down to 5mm. Contact BASF Construction Chemicals (UK) Ltd for further advice if required.

### Application Underplate:

Ensure sufficient material is available to complete the work and obtain a continuous fill.

Fill all the bolt pockets with grout before pouring the rest of the underplate grout. Pour the grout continuously from one side only to avoid air entrapment. Maintain a constant hydrostatic head of approximately 150mm, to promote flow. DO NOT vibrate. Lengths of metal or plastic strapping laid in the formwork prior to placing can be used to aid complete filling.

### Placing techniques:

Diagram (A) illustrates typical placement of MASTERFLOW® 101 in the flowable state utilising straight pouring or pumping techniques to place a bedding mortar under bearing plates.

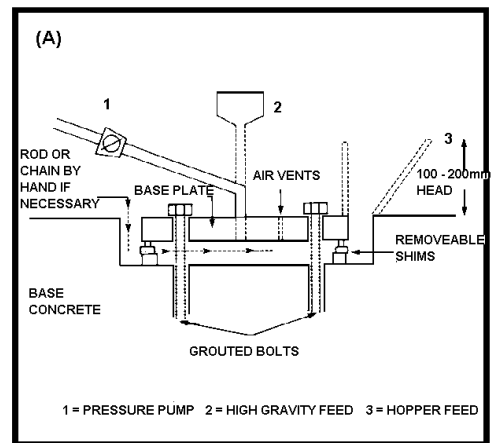

### Finishing and clean up

A smooth finish may be obtained by spraying or brushing the surface before it hardens with MASTERKURE/FEB CLEANING NO.1 SOLVENT, or other suitable solvents, approximately 1 hour after the grout is poured. Best results can be obtained by smoothing the surface several times just prior to the hardening of the grout surface.

Tools and mixer must be cleaned immediately after use with FEB CLEANING SOLVENT NO. 1 or other suitable solvents. Cured material can only be removed mechanically.

### Curing

Cure time of the grout will depend upon the temperature of the base and foundation rather than the ambient air temperature. Unless the ambient air temperature has been constant for several days the foundation temperature will generally be lower than air temperature. A surface thermometer and field judgement should be used to determine actual cure rates. Cured grout should have a solid, almost metallic ring when struck close to the base with a hammer.



The Chemical Company

#### Packaging and yield

MASTERFLOW® 101 is supplied in 5 Kg and 20 Kg units. A 5Kg pack of MASTERFLOW®101 will yield approximately 2.5 Litres of grout and a 20Kg pack will yield approximately 10 litres of grout.

When estimating due allowance for wastage must be made.

#### Storage

Store in cool dry conditions away from direct sunlight and at ambient temperatures.

#### Shelf Life

Up to 1 year when stored in unopened containers depending upon storage conditions.

Refer also to best before date.

BASF Construction Chemicals (UK) Ltd

PO Box 4

Earl Road

Cheadle Hulme

Cheadle

Cheshire

SK8 6QG

Tel: +44 (0) 161 485 6222

Fax +44 (0) 161 488 5220

[www.basf-cc.co.uk](http://www.basf-cc.co.uk)

MASTERFLOW® 101 BASF Construction Chemicals UK Ltd Version 6 – July 2007

#### Health and Safety

\*For full information on Health and Safety matters regarding this product the relevant Health and Safety Data Sheet should be consulted.

The following general comments apply to all products.

As with all chemical products, care should be taken during use and storage to avoid contact with eyes, mouth, skin and foodstuffs, (which may also be tainted with vapour until the product is fully cured and dried). Treat splashes to eyes and skin immediately. If accidentally ingested, seek medical attention. Keep away from children and animals. Reseal containers after use.

#### Solvent Based Products

Use in well ventilated areas; avoid inhaling. Suitable respiratory equipment may be needed, eg when spraying. Can cause skin, eye irritation. Wear protective eye shields and gloves during use. Do not smoke or allow sparks or naked lights when stored or in use.

#### Powder Products

Should be handled to minimise dust formation; use light mask if excessive dust unavoidable. Cement powders when wet or moistened can cause burns to skin and eyes which should be protected during use.

#### Resin Products

Can cause irritation, dermatitis or allergic reaction. Use protective equipment particularly for skin and eyes. Use only in well ventilated areas.

#### Spillage

Chemical products can cause damage; clean spillage immediately.

#### Disclaimer:

This information and all further technical advice is based on our present knowledge and experience. However, it implies no liability or other legal responsibility on our part, including with regard to existing third party intellectual property rights, especially patent rights. In particular, no warranty, whether express or implied, or guarantee of product properties in the legal sense is intended or implied. We reserve the right to make any changes according to technological progress or further developments. The customer is not released from the obligation to conduct careful inspection and testing of incoming goods. Performance of the product described herein should be verified by testing, which should be carried out only by qualified experts in the sole responsibility of a customer. Reference to trade names used by other companies is neither a recommendation, nor does it imply that similar products could not be used.